

# DEW POINT TRANSMITTER MODEL DPT-2011

BULLETIN DPT-2011



DPT-2011 Single Stage Dew Point Transmitter

## General Description

The DPT-2011 Single Stage Dew Point Transmitter uses the chilled mirror principle to determine the absolute humidity of any gas in terms of its dew- or frost-point temperature. It was specifically designed for laboratory, field and industrial process applications. The control electronics maintain the sensor mirror to the equilibrium point where a dew or frost layer is established on the mirror surface. A platinum resistance thermometer directly monitors the mirror temperature. Depending on the actual dew point, settling time from ambient may take a few seconds to one minute. A local digital display and analog and digital interfaces are provided.

## Features

- Convenient front panel digital readout
- 4-20mA analog and RS-232 digital outputs
- Rugged hard chromium mirror provides extra durability in industrial applications
- Runs from a single 12 Vdc, 2.1A supply
- LED indicates when mirror needs cleaning

## Applications

Chilled mirror dew point hygrometers are used in industrial process-control and laboratory applications to ensure product quality, including:

- Real time production process control of pharmaceutical, plate glass, paper, plastics
- Production monitoring for dried foods and dry snack processing
- Monitoring of storage environments and special purpose rooms such as museums, warehouses, computer and clean rooms
- Manufacturing quality control for fabrication of sensitive electronic components such as semiconductors
- Building HVAC or air quality monitoring

## Mirror Access

A front-mounted threaded hole plug supports access to the chilled mirror for periodic cleaning. Sample gas typically passes through the system via a flow gauge and filter tubing connections. Flow rates from 0.5 to 1.0 standard cubic feet per hour (SCFH).

## User Interface

A front panel digital panel meter indicates the current dew point temperature. A pushbutton lets you rapidly check that the mirror is clean without having to open the sensing chamber for inspection. An LED indicates when cleaning is required. Both RS-232 serial and 4-20mA analog outputs are provided. The serial interface supports a graphical LabView™ application for MS-Windows9x/NT that permits you to view real time sensor data on a PC or Mac.

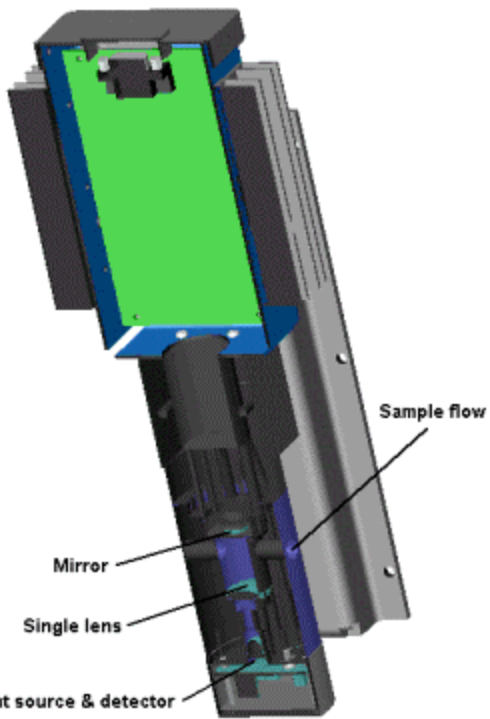

DPT-2011 cross section



DPT-2011 showing access location for mirror cleaning

## Mechanical Interface

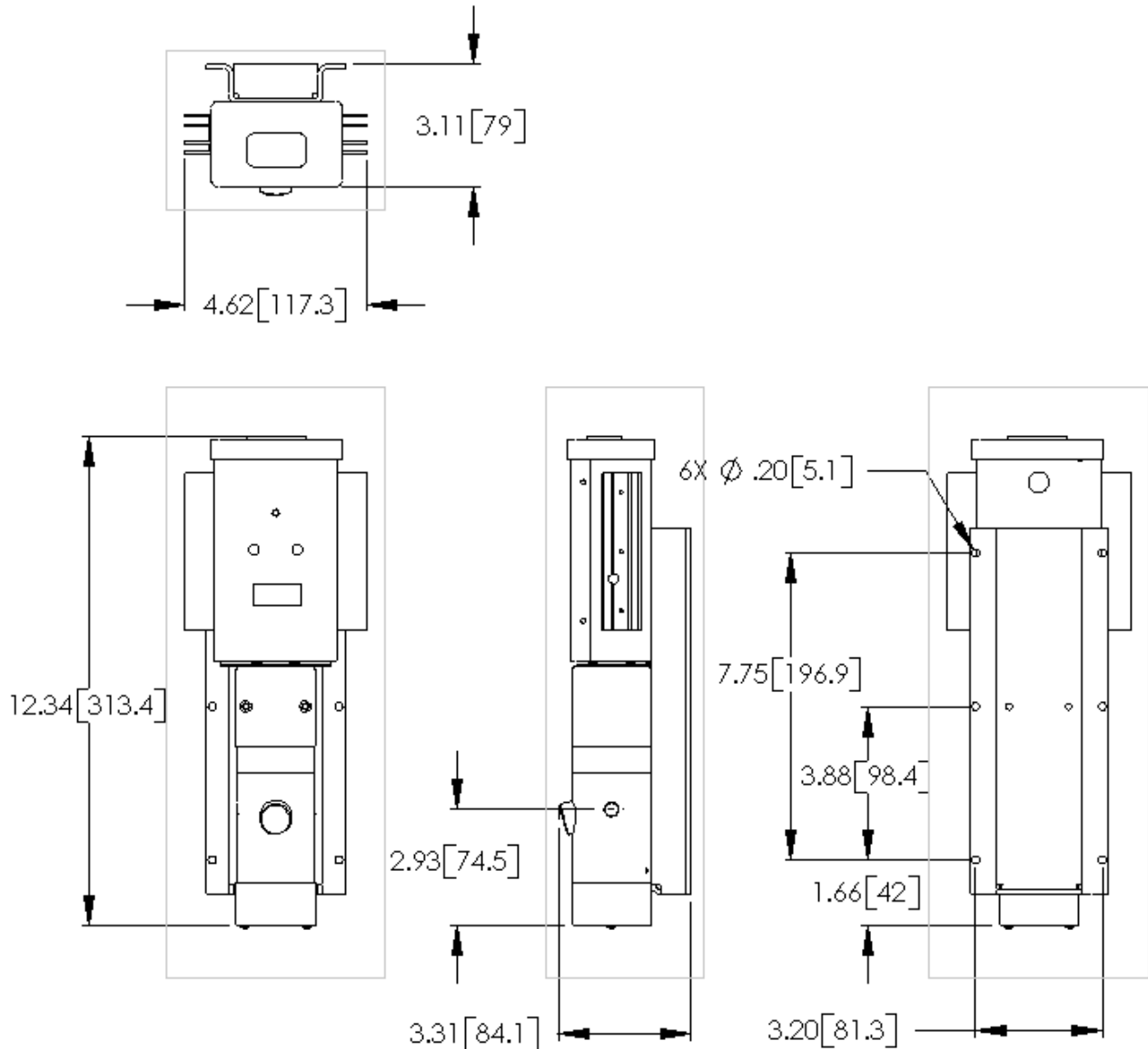

Dimensions in inches [cm]

## Specifications

Dew/frost point range	40°C depression; @22° C, dew/frost points can be measured to $\approx$ -18° C
Accuracy	$\pm$ 0.26°C
Sensitivity/Rep'y	$\pm$ 0.01°C
Pressure	0-30 PSIG
Hysteresis	None
Response time	35 seconds (typical)
Power Supply	+11 to +14 VDC, 2.1A
Gas contacts	Anodized aluminum, Viton, glass, chromium, diallyl phthalate

Output signals	10'/3 m cable 4-20mA anal, DB-9M RS232 (DTE) digital
Temperature regimes	-40°C to +50°C operating -60°C to +60°C storage (0-90%RH <i>non-condensing</i> )



**YANKEE ENVIRONMENTAL SYSTEMS, INC.**  
 Airport Industrial Park  
 101 Industrial Blvd., Turners Falls, MA 01376 USA  
 Tel: (413) 863-0200 Fax: (413) 863-0255  
 E-mail: info@yesinc.com http://www.yesinc.com